

TBR21 A.4.8.2.3 Unwanted frequency components

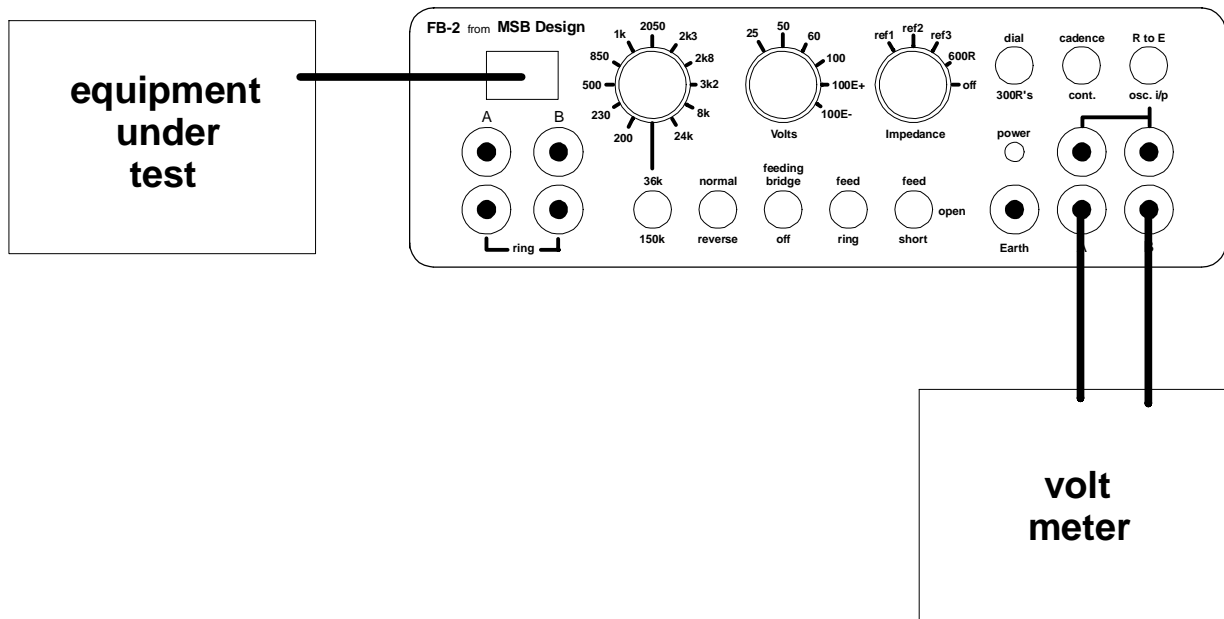

Settings :-

Feed resistance	= as needed	Voltage	= 50
Impedance	= Ref1	Dial / 300R's	= off
Dial cadence	= X	R to E / osc i/p	= X
Feed / open / short	= feed	Normal / reverse	= as needed
Ring / feed	= feed	Feeding Bridge	= on

X means "don't care"

The apparatus under test (AUT) is plugged into the FB-2, and the controls are set as shown.

Measure the level of various frequency bands.