

## TBR21 A.4.8.2.1 Frequency combinations

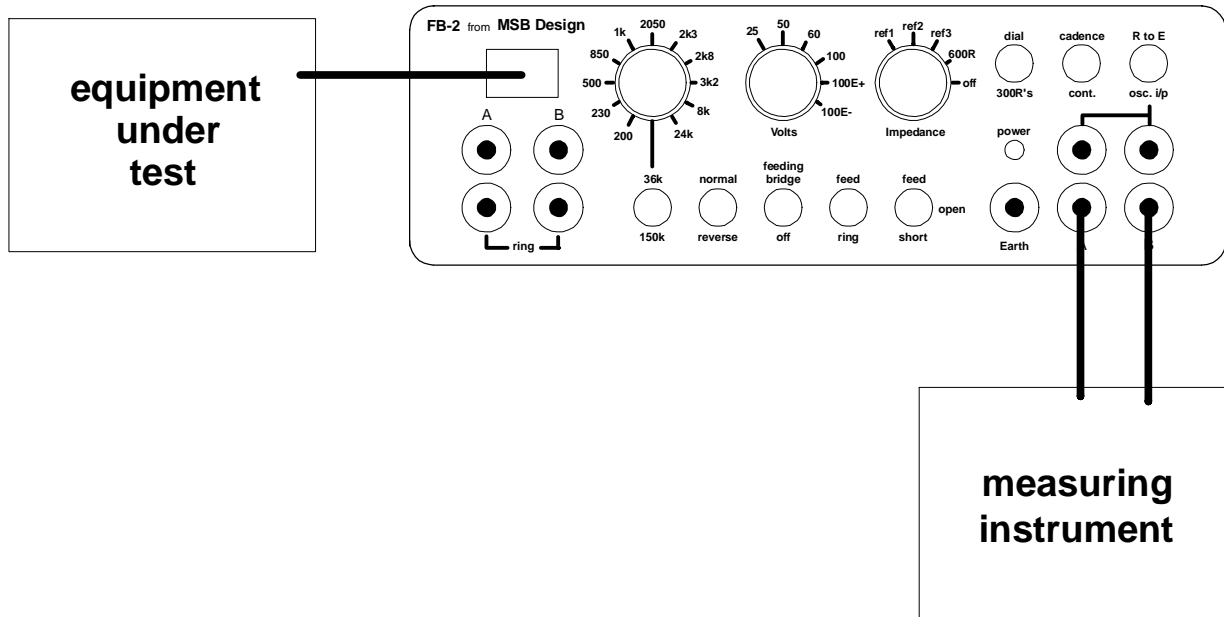

### Settings :-

Feed resistance	= 850 ohms	Voltage	= 50
Impedance	= Ref1	Dial / 300R's	= if needed
Dial cadence	= as needed	R to E / osc i/p	= X
Feed / open / short	= feed	Normal / reverse	= X
Ring / feed	= feed	Feeding Bridge	= on

X means "don't care"

The apparatus under test ( AUT ) is plugged into the FB-2, and the controls are set as shown.

Measure the digit frequencies.