

TBR21 A.4.4.1 DC Resistance

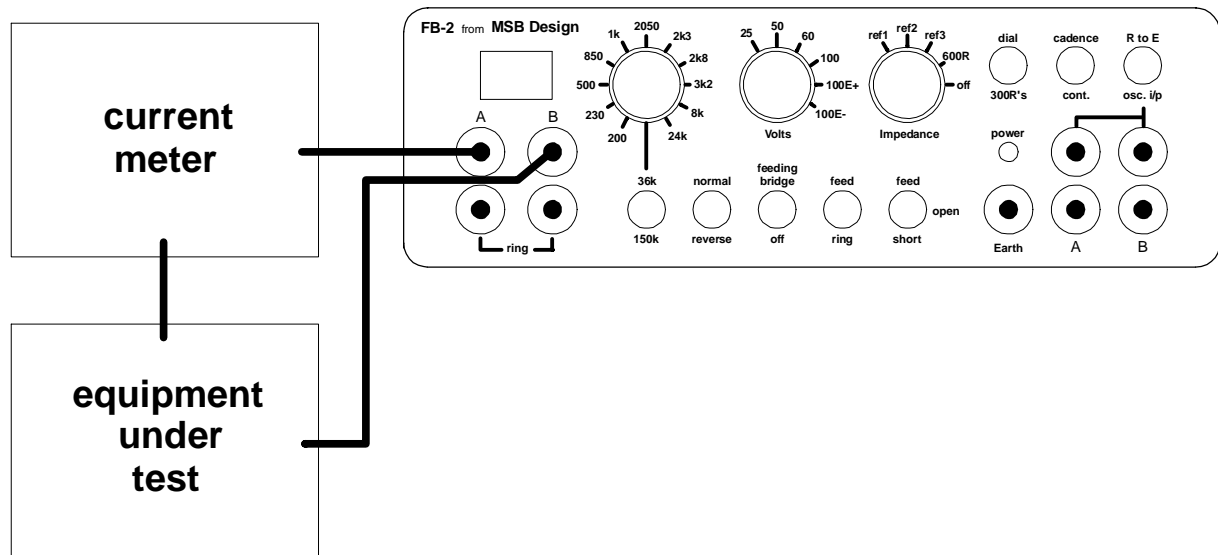

Settings :-

Feed resistance	= 200 ohms	Voltage	= 25, 50 & 100
Impedance	= off	Dial / 300R's	= off
Dial cadence	= off	R to E / osc i/p	= X
Feed / open / short	= feed	normal / reverse	= as needed
ring / feed	= feed	feeding bridge	= off

X means "don't care"

The apparatus under test (AUT) is plugged into the FB-2, and the controls are set as shown.

Measure the current for the various voltages, as required.