

BS6317 Test B.1 Sending sensitivity test

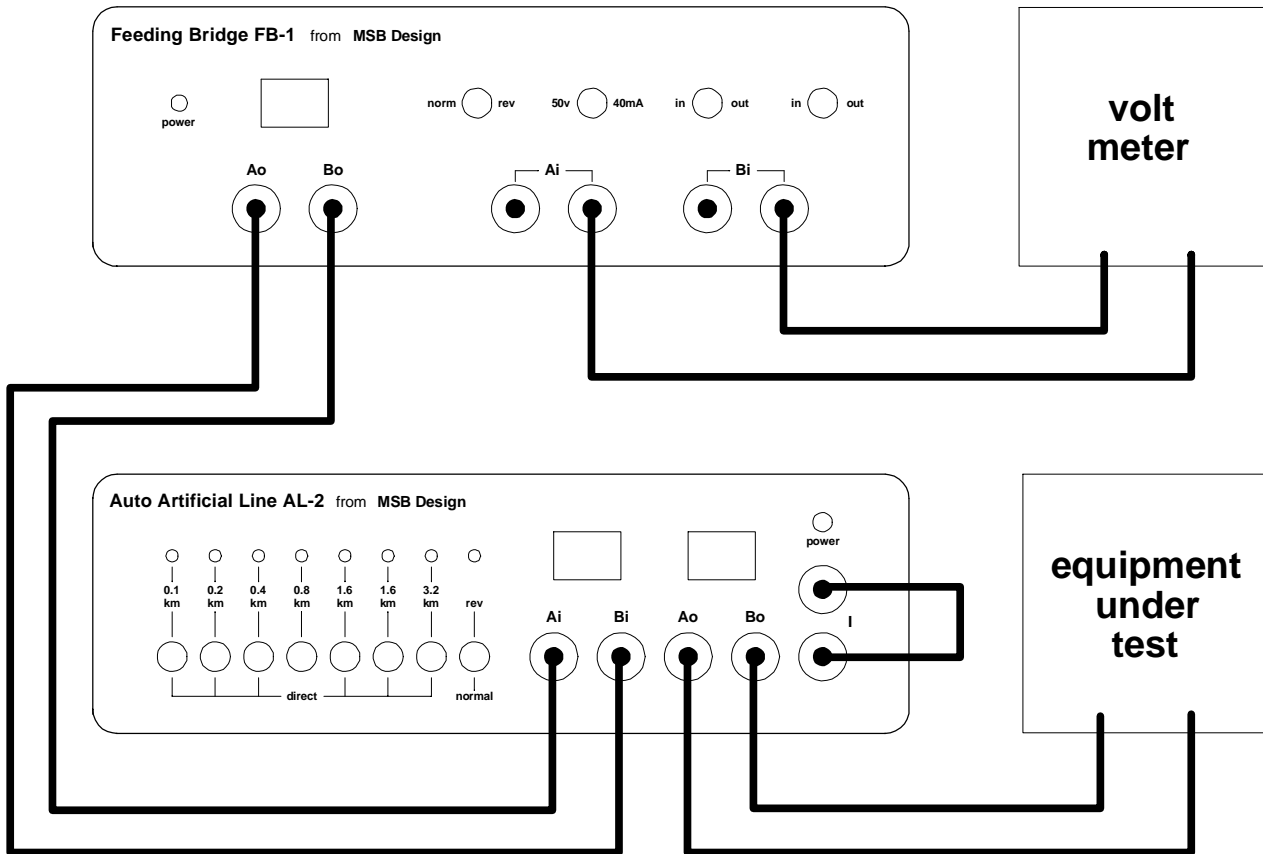

Settings :-

- set the FB-1 feed to 50 volts
- switch Rp in circuit and Rs out
- select AL-2 line lengths as needed

Measure the voltage at various line lengths, as specified in the test definition.

The Artificial Line AL-1 is equally suitable for this application.