

BS6305 Test A.8 Pulse distortion tests

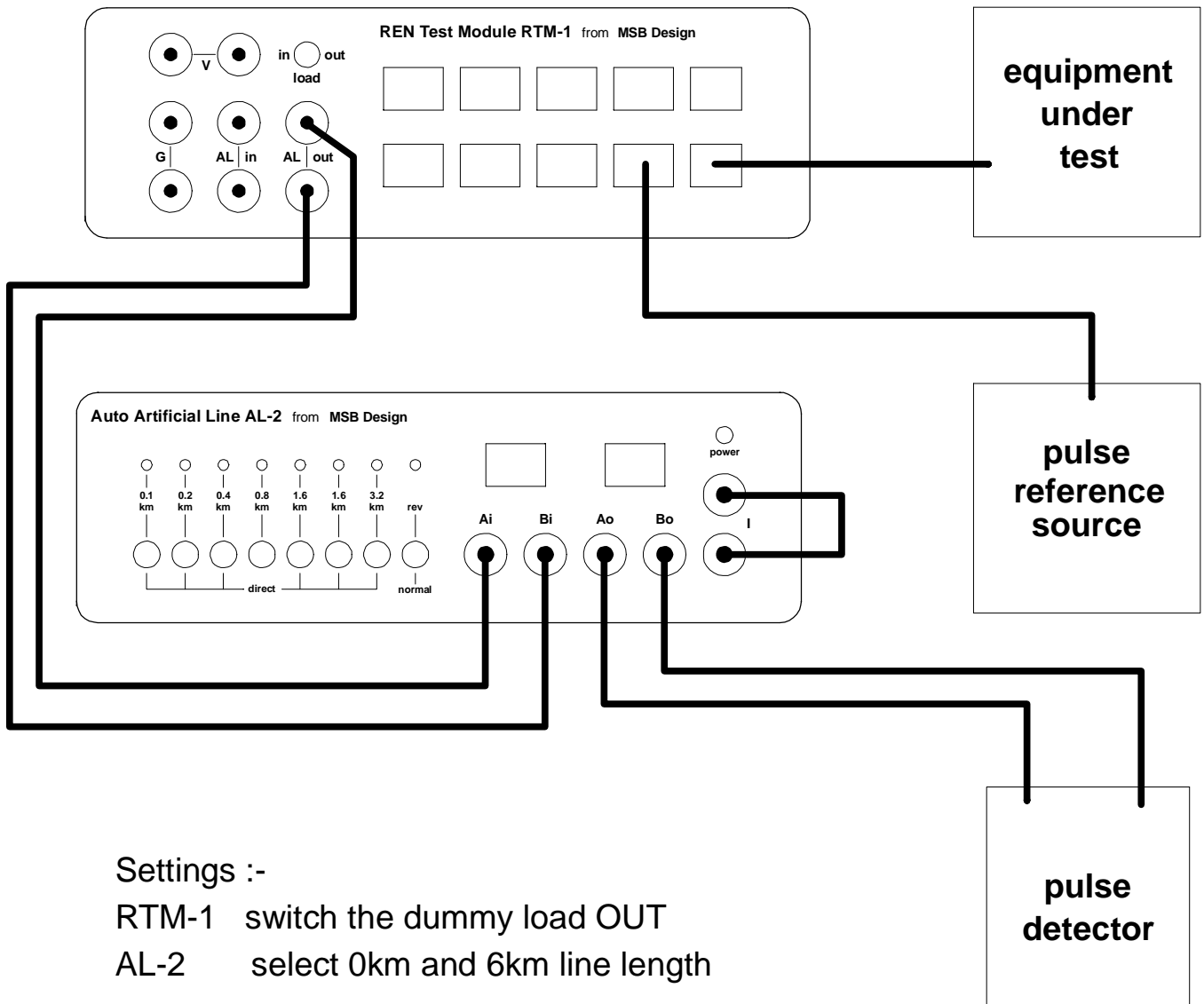

The apparatus under test is plugged into any one of the sockets on the REN Test Module RTM-1. The AL-2 Artificial Line input is connected to the RTM-1 ALout terminals, and the pulse detector circuitry is connected to the artificial line output terminals.

Note that the Artificial Line AL-1 is equally suitable for this application.

In both cases the two current sense terminals should be linked together, as shown. The pulse reference source is connected to another socket on the RTM-1.

Tests are carried out both with the reference pulses active and the equipment under test (EUT) idle, and vice versa.