

TBR21 A.4.5 Ringing signal detector sensitivity

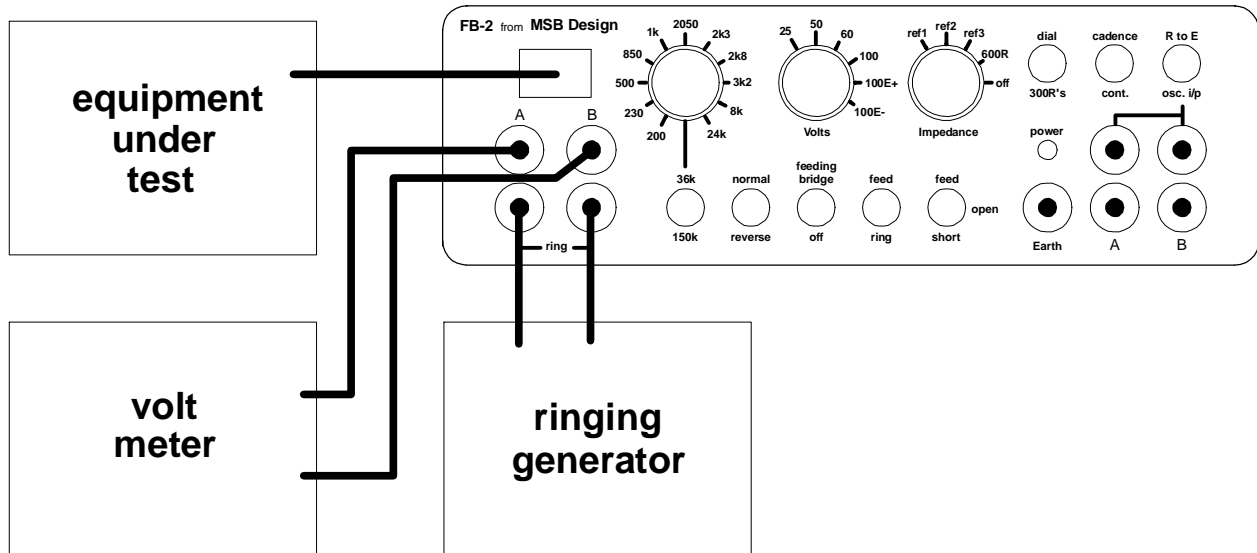

Settings :-

Feed resistance	= 850	Voltage	= X
Impedance	= off	Dial / 300R's	= off
Dial cadence	= X	R to E / osc i/p	= X
Feed / open / short	= feed	Normal / reverse	= X
Ring / feed	= ring	Feeding Bridge	= off

X means "don't care"

The apparatus under test (AUT) is plugged into the FB-2, and the controls are set as shown.

The ringing should be dc backed by 50v.

Observe the ringing detection.