

TBR21 A.4.4.3 Impedance unbalance about earth

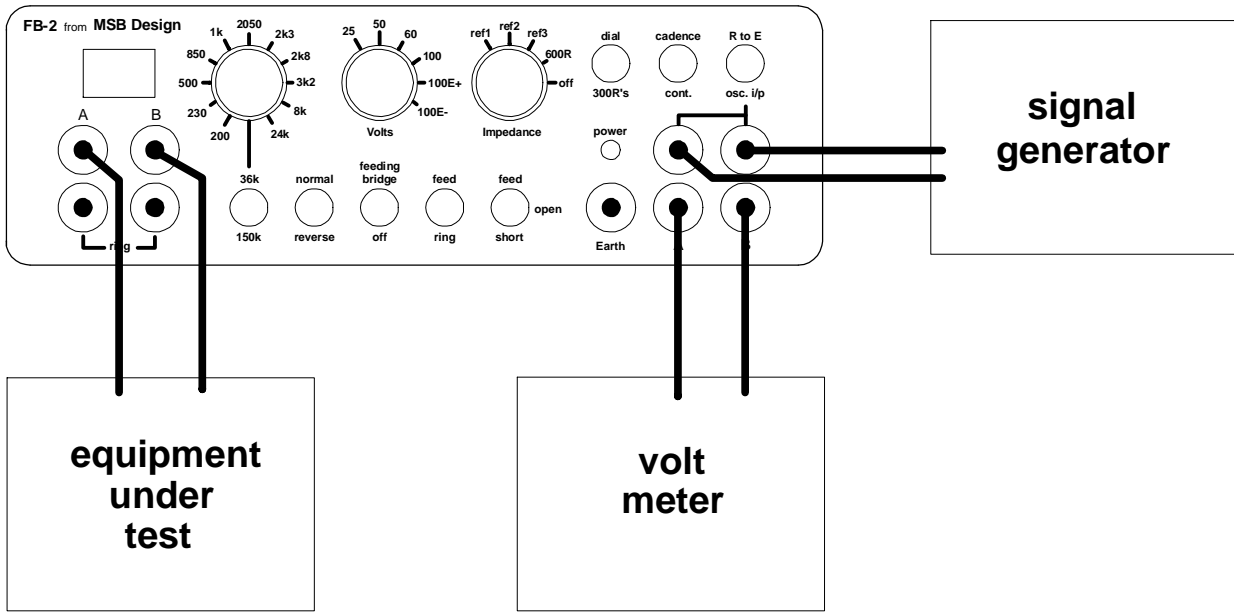

Settings :-

Feed resistance	= 230 ohms	Voltage	= 50
Impedance	= off	Dial / 300R's	= 300R's
Dial cadence	= X	R to E / osc i/p	= osc i/p
Feed / open / short	= feed	Normal / reverse	= as needed
Ring / feed	= feed	Feeding Bridge	= on

X means "don't care"

The apparatus under test (AUT) is plugged into the FB-2, and the controls are set as shown.

Measure the voltage for various frequencies, as specified in the test definition.